



**INTERCONNECTION
FACILITIES STUDY
REPORT**

GEN-2023-SR19

Published March 2026

By SPP Generator Interconnections Special Studies Dept.

CONTENTS

Summary	1
Introduction	1
Phase(s) of Interconnection Service	1
Compensation for Amounts Advanced for Network Upgrade(s).....	1
Interconnection Customer Interconnection Facilities	2
Transmission Owner Interconnection Facilities and Non-Shared Network Upgrade(s).....	3
Conclusion.....	4
Appendices.....	5
A: Transmission Owner’s Interconnection Facilities Study Report and Network Upgrades Report(s).....	5

SUMMARY

INTRODUCTION

This Interconnection Facilities Study (IFS) for Interconnection Request GEN-2023-SR19 is for a 50 MW generating facility located in Jefferson County, NE. The Interconnection Request was studied in the Surplus Impact Study for ERIS. The Interconnection Customer's requested in-service date is 09/08/2026.

The interconnecting Transmission Owner, Nebraska Public Power District (NPPD), performed a detailed IFS at the request of SPP. The full report is included in Appendix A. SPP has determined that full Interconnection Service will be available after the assigned Transmission Owner Interconnection Facilities (TOIF), and Non-Shared Network Upgrades that are required for full interconnection service are completed.

The primary objective of the IFS is to identify necessary Transmission Owner Interconnection Facilities, other direct assigned upgrades, cost estimates, and associated upgrade lead times needed to grant the requested Interconnection Service.

PHASE(S) OF INTERCONNECTION SERVICE

It is not expected that Interconnection Service will occur in phases. However, full Interconnection Service will not be available until all Interconnection Facilities and Network Upgrade(s) can be placed in service.

COMPENSATION FOR AMOUNTS ADVANCED FOR NETWORK UPGRADE(S)

FERC Order ER20-1687-000 eliminated the use of Attachment Z2 revenue crediting as an option for compensation. The Incremental Long Term Congestion Right (ILTCR) process will be the sole process to compensate upgrade sponsors as of July 1st, 2020.

INTERCONNECTION CUSTOMER INTERCONNECTION FACILITIES

The Generating Facility is proposed to consist of seventeen (17) GE FLEX 1571 2.972 MW Battery Energy Storage System (BESS) inverters for a total generating nameplate capacity of 50.524 MW which exceeds the requested Surplus Interconnection Service of 50 MW. The sum of the output from the combined generation of GEN-11-018, GEN-2013-008, GEN-2014-004 and GEN-2023-SR19 are limited at the Point of Interconnection to 78.76 MW.

The Interconnection Customer's Interconnection Facilities to be designed, procured, constructed, installed, maintained, and owned by the Interconnection Customer at its sole expense include:

- 34.5 kV underground cable collection circuits;
- The project will connect to the existing main collector substation and share the main power transformer to connect to the Point of Interconnection (POI) at the 115 kV bus at the existing Transmission Owner substation (Steele City 115 kV) that is owned and maintained by Transmission Owner;
- All transmission facilities required to connect the Interconnection Customer's substation to the POI;
- Equipment at the Interconnection Customer's substation necessary to maintain a composite power delivery at continuous rated power output at the high-side of the generator substation at a power factor within the range of 95% lagging and 95% leading in accordance with Federal Energy Regulatory Commission (FERC) Order 827. Additionally, needed approximately 0.8 Mvars¹ of reactors to compensate for injection of reactive power into the transmission system under no/reduced generating conditions. The Interconnection Customer may use inverter manufacturing options for providing reactive power under no/reduced generation conditions. The Interconnection Customer will be required to provide documentation and design specifications demonstrating how the requirements are met; and,
- All necessary relay, protection, control and communication systems required to protect Interconnection Customer's Interconnection Facilities and Generating Facilities and coordinate with Transmission Owner's relay, protection, control and communication systems.

¹ This approximate minimum reactor amount is needed for the current configuration of GEN-2023-SR19 as studied in the Surplus Impact Study.

TRANSMISSION OWNER INTERCONNECTION FACILITIES AND NON-SHARED NETWORK UPGRADE(S)

To facilitate interconnection, the interconnecting Transmission Owner will perform work as shown below necessary for the acceptance of the Interconnection Customer’s Interconnection Facilities.

Table 1 and **Table 2** list the Interconnection Customer’s estimated cost responsibility for Transmission Owner Interconnection Facilities (TOIF) and Non-Shared Network Upgrade(s) and provides an estimated lead time for completion of construction. The estimated lead time begins when the Generator Interconnection Agreement has been fully executed.

Table 1: Transmission Owner Interconnection Facilities (TOIF)

Transmission Owner Interconnection Facilities (TOIF)	Total Cost Estimate (\$)	Allocated Percent (%)	Allocated Cost Estimate (\$)
<u>Transmission Owner’s Interconnection (TOIF):</u> Add additional metering and interconnection monitoring requirements for the Battery/Storage generating.	\$600,00	100%	\$600,000
<u>Estimated Lead Time: 24 Months</u>			
Total	\$600,000		\$600,000

Table 2: Non-Shared Network Upgrade(s)

Non-Shared Network Upgrades Description	ILTCR	Total Cost Estimate (\$)	Allocated Percent (%)	Allocated Cost Estimate (\$)
<u>None</u>		\$0	100.00%	\$0
Total		\$ 0		\$ 0

CONCLUSION

After all Interconnection Facilities and Network Upgrades have been placed into service, Interconnection Service for 50 MW can be granted. Full Interconnection Service will be delayed until the TOIF, and Non-Shared NU that are required for full interconnection service are completed. The Interconnection Customer’s estimated cost responsibility for full interconnection service is summarized in the table below.

Table 3: Cost Summary

Description	Allocated Cost Estimate
Transmission Owner Interconnection Facilities Upgrade(s)	\$600,000
Non-Shared Network Upgrade(s)	\$ 0
Total	\$600,000

Use the following link for Quarterly Updates on upgrades from this report: <https://spp.org/spp-documents-filings/?id=18641>

A draft Generator Interconnection Agreement will be provided to the Interconnection Customer consistent with the results of this IFS report. The Transmission Owner and Interconnection Customer will have 60 days to negotiate the terms of the GIA consistent with the SPP Open Access Transmission Tariff (OATT).

APPENDICES

A: TRANSMISSION OWNER'S INTERCONNECTION FACILITIES STUDY REPORT AND NETWORK UPGRADES REPORT(S)

See next page for the Transmission Owner's Interconnection Facilities Study Report and Network Upgrades Report(s).

**NPPD
GEN-2023-SR19
FACILITY STUDY**

**50 MW
Steele Flats Wind ESR**

MARCH 2026

**PREPARED FOR:
SOUTHWEST POWER POOL**

**PREPARED BY:
NEBRASKA PUBLIC POWER DISTRICT
ENERGY DELIVERY
TRANSMISSION ASSET PLANNING
ENGINEERING & ASSET MANAGEMENT**



Nebraska Public Power District

"Always there when you need us"

Introduction

The *NPPD GEN-2023-SR19 Facility Study* was performed to document the interconnection facilities and network upgrades for the following ESR request:

GEN-2023-SR19

50 MW ESR at NPPD Steele City 115 kV

Surplus Generating Facility:

GEN-2011-018,

GEN-2013-008,

GEN-2014-004 – 78.76 MW Steele Flats Wind

NPPD performed this Facility Study for the ESR as a Transmission Owner per the request of SPP as the Planning Coordinator and Transmission Service Provider. SPP previously contracted with Aneden Consulting to perform the surplus service impact study for the subject ESR. SPP performed a CLOSIS for the subject ESR per BP 7250. It should be noted that these studies do not establish firm transmission service for the ESR request and a separate transmission service request must be submitted and approved by SPP (as the transmission service provider) to achieve firm transmission service.

Interconnection Facility and Network Upgrades

NPPD's Engineering, Asset Management, and Project Management groups have reviewed the interconnection facility upgrades that are required for the SPP GEN-2023-SR19 project. Detailed cost estimates have been prepared for the facility upgrades that were identified in the system impact study for the requests. The prepared cost estimates are study level estimates (+20%/-20%) and assume implementation of standard NPPD construction and procurement practices. The cost estimates for the interconnection facilities are below:

Interconnection Facility Upgrades

- Steele City 115 kV Substation
 - Additional metering and interconnection monitoring requirements
 - 24 Month Lead Time

\$ 600,000

Preliminary one-line diagrams for the local area and each generation interconnection project are in Appendix 1.

Interconnection Facilities and Network Upgrade project schedule details will be further discussed in the development of the generator interconnection agreements (GIA) and the milestones associated with the generation interconnection projects.

Operational Limitations

SPP and its consultants have studied the injection of the ESR in accordance with the SPP tariff to provide interconnection service for the ESR request. NPPD has elected to not perform a LCS study due to the duplicative approach with the SPP CLOSI studies and the prescribed modeling methodology in business practice 7250, plus the stated desire of SPP to not require network upgrades. Business practice 7250 requires the LCS use off-peak HVER cases which utilize the inadequate Fuel Based Dispatch and are not likely the constrained modelling cases for serving ESR charging load. So essentially any NPPD LCS study must duplicate the SPP CLOSI study approach. In the amended FERC ESR-LA filings, it was stated “... SPP is not proposing to assign Network Upgrades to accommodate the charging of the ESR and is instead providing a charging limit representing the amount of change in megawatts that can be accommodated without requiring Network Upgrades.”

Per the FERC filings, an “Appendix H to GIA-Operating Assumptions for the Generating Facility” will be applicable for these ESR’s. NPPD would expect specific load levels documented for the operating assumptions rather than the generic “off-peak system conditions” shown in the amended FERC filing. If the ESR desires to “self-charge” per attachment AE, then it would be required to make a Transmission Service Request or applicable request under Attachment AQ.

The ESR shall be limited to the injection level of the associated generation interconnection requests combined with the existing generation interconnection request at each location. For GEN-2023-SR19, the injection level is limited to 78.76 MW for the combined ESR/GI dispatch of Steele Flats Wind.

From a charging perspective, the ESR has only been studied at Light Load conditions per SPP BP7250 and operations would be limited to these studied conditions. If NPPD system load exceeds 1600 MW, then this is an unstudied condition for ESR charging that could result in an unreliable system condition that would need to be mitigated by NPPD system operators. Also, local prior outage conditions and/or unplanned operations could dictate ESR charging limitations to maintain system reliability.

Short Circuit Impacts

NPPD's Engineering group has reviewed the short circuit impacts of the SPP GEN-2023-SR19 project. Due to the operational limitations documented above and the additions being behind the existing main power transformers and the max output not going above the previously studied MW, the max fault current at NPPD substations should not change significantly. The short circuit impacts are not significant, and no additional work is required to mitigate the impacts.

Appendix 1

ESR One-Line Diagram

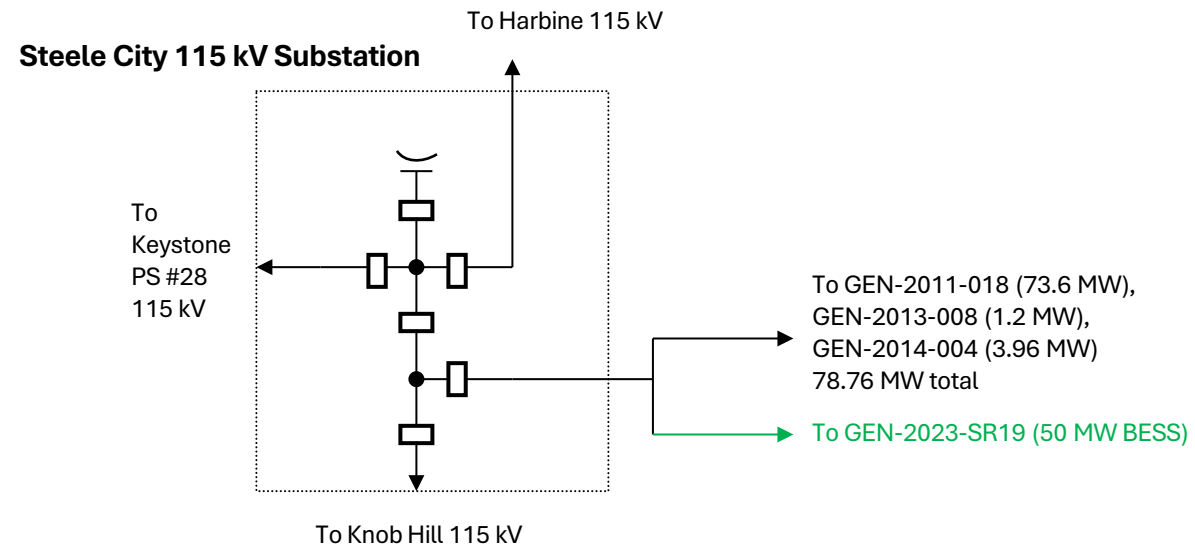

- GEN-2013-SR19 ESR using GEN-2011-018, GEN-2013-008, GEN-2014-004